

ЭКСКЛЮЗИВНЫЙ ДИЛЕР НА ТЕРРИТОРИИ РФ И СТРАН СНГ:

ООО «ОТТИМО-ТУЛЗ»
www.ottimo-tools.ru

Отдел продаж:
Sales@ottimo-tools.ru
Техническая поддержка:
Tech@ottimo-tools.ru

Санкт-Петербург:
Тел.: +7 (812) 628-13-26
Москва:
Тел.: +7 (495) 188-13-26

194292, Санкт-Петербург,
Пр-кт Культуры, д.44,
лит. А, оф. 302

MODELLE МОДЕЛЬ	FORZA NOMINALE УСИЛИЕ НОМИНАЛЬНОЕ kN	FORZA MASSIMA УСИЛИЕ МАКСИМАЛЬНОЕ kN	LUNGHEZZA TAVOLA ДЛИНА СТОЛА L mm	PASSAGGIO MONTANTI РАССТОЯНИЕ МЕЖДУ СТОЙКАМИ P mm	INCAVO MONTANTI ВЫЛЕТ (ВЫРЕЗ В СТОЙКАХ) I mm	DISTANZA TAVOLA PESTONE ОТКРЫТАЯ ВЫСОТА H mm	CORSA MAX ХОД ТРАВЕРСЫ mm	CORSA ASSE X ХОД ПО ОСИ X mm	CORSA ASSE R ХОД ПО ОСИ R mm	СКОРОСТЬ ПОДВОДА ТРАВЕРСЫ mm/s	VELOCITÀ DI LAVORO РАБОЧАЯ СКОРОСТЬ mm/s	VELOCITÀ DI RITORNO СКОРОСТЬ ВОЗВРАТА mm/s	A mm	B mm	C mm	D mm	E mm	POTENZA COMPLESSIVA МОТОРИ ОБЩАЯ МОЩНОСТЬ ПРИВОДА kW	PESO APPROSSIMATIVO МАССА ОРИЕНТИРОВОЧНО kg	MODELLE МОДЕЛЬ
PS 0838	380	420	835	850	175	430	220	500	150	275	1 ÷ 12	330	2600	1450	2822	-	-	5	3600	PS 0838
PS 1550	500	600	1600	1200	300	410	200	500	150	200	1 ÷ 12	200	3000	1450	2500	-	-	7,5	4200	PS 1550
PS 250	500	600	2200	1600	500	410	200	750	150	200	1 ÷ 12	200	3900	1700	2600	-	-	7,5	4500	PS 250
PS 275	750	850	2200	1600	500	430	220	750	150	275	1 ÷ 12	250	3900	1750	2650	-	-	7,5	6300	PS 275
PS-C 290	900	1200	2200	1600	500	430	220	800	150	285	1 ÷ 12	250	3950	1800	2650	-	-	9,2	8650	PS-C 290
PS-C 390	900	1200	3200	2600	500	430	220	800	150	285	1 ÷ 12	220	4900	1900	2800	-	-	9,2	10100	PS-C 390
PS-C 490	900	1200	4200	3600	500	430	220	800	150	280	1 ÷ 12	175	5900	1900	2800	-	-	9,2	12400	PS-C 490
PS-C 590	900	1200	5200	4200	500	430	220	800	200	200	1 ÷ 12	120	6900	1900	3000	-	-	9,2	14600	PS-C 590
PS-C 690	900	1200	6200	5200	500	430	220	800	200	200	1 ÷ 12	120	7900	1900	3000	-	-	9,2	19000	PS-C 690
PS-C 2120	1200	1600	2200	1600	500	430	220	800	150	240	1 ÷ 12	240	3900	1900	2850	-	-	11	10000	PS-C 2120
PS-C 3120	1200	1600	3200	2600	500	430	220	800	150	300	1 ÷ 12	230	4900	1900	2850	-	-	11	12700	PS-C 3120
PS-C 4120	1200	1600	4200	3600	500	430	220	800	150	300	1 ÷ 12	210	6000	1900	2850	-	-	11	14500	PS-C 4120
PS-C 5120	1200	1600	5200	4200	500	430	220	800	200	210	1 ÷ 12	120	6900	2000	2850	-	-	11	17000	PS-C 5120
PS-C 6120	1200	1600	6200	5200	500	430	220	800	200	210	1 ÷ 12	110	7900	2000	2850	-	-	11	21800	PS-C 6120
PS-C 2160	1600	2000	2200	1600	500	430	220	800	150	160	1 ÷ 12	200	4000	2050	2850	-	-	15	11500	PS-C 2160
PS-C 3160	1600	2000	3200	2600	500	430	220	800	150	160	1 ÷ 12	160	5000	2050	2850	-	-	15	14000	PS-C 3160
PS-C 4160	1600	2000	4200	3600	500	430	220	800	150	160	1 ÷ 12	160	6000	2050	2950	-	-	15	16800	PS-C 4160
PS-C 5160	1600	2000	5200	4200	500	430	220	800	200	160	1 ÷ 12	140	6900	2050	2950	-	-	15	19500	PS-C 5160
PS-C 6160	1600	2000	6200	5200	500	430	220	800	200	160	1 ÷ 12	130	7900	2450	3400	-	-	15	24500	PS-C 6160
PS-C 3200	2000	2550	3200	2600	500	510	300	800	150	200	1 ÷ 12	200	4900	2150	3200	-	-	18,5	18200	PS-C 3200
PS-C 4200	2000	2550	4200	3600	500	510	300	800	150	200	1 ÷ 12	180	5900	2150	3200	-	-	18,5	21600	PS-C 4200
PS-C 5200	2000	2550	5200	4200	500	510	300	800	150	200	1 ÷ 12	160	6900	2150	3200	-	-	18,5	25600	PS-C 5200
PS-C 6200	2000	2550	6200	5200	500	510	300	800	200	200	1 ÷ 12	160	7900	2150	3400	-	-	18,5	29100	PS-C 6200
PS-C 3300	3000	3400	3200	2600	500	560	300	800	200	130	1 ÷ 12	145	4900	2300	3400	-	-	22	22500	PS-C 3300
PS-C 4300	3000	3400	4200	3600	500	560	300	800	200	160	1 ÷ 12	145	5900	2300	3400	-	-	22	26700	PS-C 4300
PS-C 5300	3000	3400	5200	4200	500	560	300	800	200	160	1 ÷ 12	130	6900	2300	3500	-	-	22	31000	PS-C 5300
PS-C 6300	3000	3400	6200	5200	500	560	300	800	200	160	1 ÷ 12	130	7900	2300	3600	-	-	22	33500	PS-C 6300
PS-C 4400	4000	4450	4200	3600	500	660	400	800	200	130	1 ÷ 12	150	5900	2400	3550	-	-	30	30000	PS-C 4400
PS-C 5400	4000	4450	5200	4200	500	660	400	800	200	130	1 ÷ 12	130	6900	2400	3500	400	-	30	35000	PS-C 5400
PS-C 6400	4000	4450	6200	5200	500	660	400	800	200	130	1 ÷ 12	130	7900	2400	3600	500	-	30	41000	PS-C 6400
PS-C 4500	5000	5550	4200	3600	500	730	400	800	200	130	1 ÷ 12	160	5900	2500	3800	250	250	37	40000	PS-C 4500
PS-C 5500	5000	5550	5200	4200	500	730	400	800	200	130	1 ÷ 12	150	6900	2500	4000	400	250	37	48000	PS-C 5500
PS-C 6500	5000	5550	6200	5200	500	730	400	800	200	130	1 ÷ 12	140	7900	2500	4000	600	250	55	54300	PS-C 6500
PS-C 4600	6000	6500	4200	3600	500	730	400	800	200	130	1 ÷ 9	140	5900	2500	3900	450	250	55	43500	PS-C 4600
PS-C 5600	6000	6500	5200	4200	500	730	400	800	200	130	1 ÷ 9	130	6900	2500	4100	650	250	55	53000	PS-C 5600
PS-C 6600	6000	6500	6200	5200	500	730	400	800	200	130	1 ÷ 9	120	7900	2500	4100	800	250	55	59000	PS-C 6600
PS-C 6800	8000	8000	6200	5200	500	830	550	1000	250	100	1 ÷ 8	100	7900	3100	4600	1050	700	55	77000	PS-C 6800
PS-C 8800	8000	8000	8200	7200	500	830	550	1000	250	100	1 ÷ 8	100	10000	3100	4900	1300	700	55	91000	PS-C 8800
PS-C 10800	8000	8000	10200	8500	500	830	550	1000	250	100	1 ÷ 8	100	12000	3100	5100	1700	700	55	110000	PS-C 10800
PS-C 81100	11000	11000	8200	7200	500	930	550	1000	250	100	1 ÷ 8	100	10000	3500	5200	1500	850	75	115000	PS-C 81100
PS-C 101100	11000	11000	10200	8500	500	930	550	1000	250	100	1 ÷ 8	100	12000	3500	5500	2000	850	75	137000	PS-C 101100

A	B	C	D	E	POTENZA COMPLESSIVA MOTORI ОБЩАЯ МОЩНОСТЬ ПРИБОДА	PESO APPROSSIMATIVO MACCA ОРИЕНТИРОВОЧНО	MODELLI МОДЕЛЬ
mm	mm	mm	mm	mm	kW	kg	
2600	1450	2822	-	-	5	3600	PS 0838
3000	1450	2500	-	-	7,5	4200	PS 1550
3900	1700	2600	-	-	7,5	4500	PS 250
3900	1750	2650	-	-	7,5	6300	PS 275
3950	1800	2650	-	-	9,2	8650	PS-C 290
4900	1900	2800	-	-	9,2	10100	PS-C 390
5900	1900	2800	-	-	9,2	12400	PS-C 490
6900	1900	3000	-	-	9,2	14600	PS-C 590
7900	1900	3000	-	-	9,2	19000	PS-C 690
3900	1900	2850	-	-	11	10000	PS-C 2120
4900	1900	2850	-	-	11	12700	PS-C 3120
6000	1900	2850	-	-	11	14500	PS-C 4120
6900	2000	2850	-	-	11	17000	PS-C 5120
7900	2000	2850	-	-	11	21800	PS-C 6120
4000	2050	2850	-	-	15	11500	PS-C 2160
5000	2050	2850	-	-	15	14000	PS-C 3160
6000	2050	2950	-	-	15	16800	PS-C 4160
6900	2050	2950	-	-	15	19500	PS-C 5160
7900	2450	3400	-	-	15	24500	PS-C 6160
4900	2150	3200	-	-	18,5	18200	PS-C 3200
5900	2150	3200	-	-	18,5	21600	PS-C 4200
6900	2150	3200	-	-	18,5	25600	PS-C 5200
7900	2150	3400	-	-	18,5	29100	PS-C 6200
4900	2300	3400	-	-	22	22500	PS-C 3300
5900	2300	3400	-	-	22	26700	PS-C 4300
6900	2300	3500	-	-	22	31000	PS-C 5300
7900	2300	3600	-	-	22	33500	PS-C 6300
5900	2400	3550	-	-	30	30000	PS-C 4400
6900	2400	3500	400	-	30	35000	PS-C 5400
7900	2400	3600	500	-	30	41000	PS-C 6400
5900	2500	3800	250	250	37	40000	PS-C 4500
6900	2500	4000	400	250	37	48000	PS-C 5500
7900	2500	4000	600	250	55	54300	PS-C 6500
5900	2500	3900	450	250	55	43500	PS-C 4600
6900	2500	4100	650	250	55	53000	PS-C 5600
7900	2500	4100	800	250	55	59000	PS-C 6600
7900	3100	4600	1050	700	55	77000	PS-C 6800
10000	3100	4900	1300	700	55	91000	PS-C 8800
12000	3100	5100	1700	700	55	110000	PS-C 10800
10000	3500	5200	1500	850	75	115000	PS-C 81100
12000	3500	5500	2000	850	75	137000	PS-C 101100

OTTIMO tools

Sheet metal tooling and machinery
Technology and Solutions

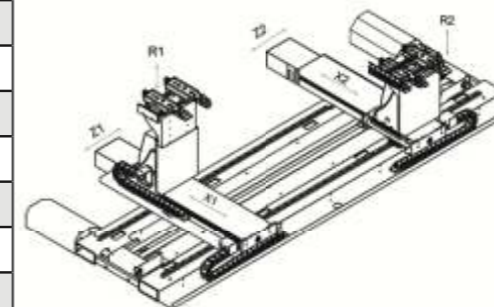
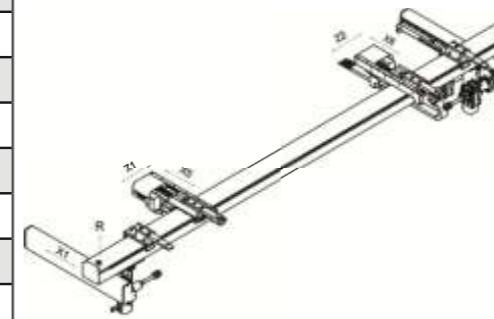
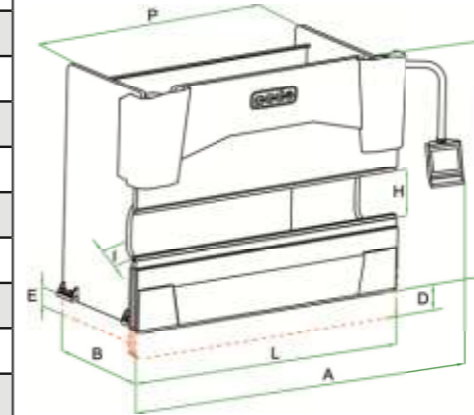

ЭКСКЛЮЗИВНЫЙ ДИЛЕР НА ТЕРРИТОРИИ РФ И СТРАН СНГ:

OTTIMO tools

ООО «ОТТИМО-ТУЛЗ»
www.ottimo-tools.ru

✉ Отдел продаж:
Sales@ottimo-tools.ru
Техническая поддержка:
Tech@ottimo-tools.ru

☎ Санкт-Петербург:
Тел.: +7 (812) 628-13-26
Москва:
Тел.: +7 (495) 188-13-26

📍 194292, Санкт-Петербург,
Пр-кт Культуры, д.44,
лит. А, оф. 302